

Orbitor 4 Nozzle

industrial & hygienic tank washing machine



Description

The Orbitor 4 Nozzle delivers a dense wash pattern for an exceptional clean at the highest CIP standards required in the food, brewing, beverage, dairy & chemical industries.

The machine is designed to fully self-clean during operation. Its profile's rounded contouring and smoothness of finish ensures no residue can be trapped in the outer or inner mechanism. With seals that self-flush and the cleaning media itself lubricating the gear box, there is no risk of contamination or product build up. Due to the Orbitor's low starting torque it can also be used with low supply pressures.

To achieve 100% efficient cleaning with the minimum possible water consumption, each machine is custom made / configured to order, matching cycle times, available operating pressure and flow rate requirements.

The Orbitor 4 Nozzle is available in 2 finishes: standard for general industrial purposes & highly polished (0.8Ra internal; 0.5Ra external) for hygienic use. ATEX certification is available on request.

Range	Orbitor 100	Orbitor 4 Nozzle	Orbitor Double Nozzle	Orbitor Dual Head	Orbitor Hi Cap	Orbitor DT
Tank Ø	< 5m - 12m	< 10m - 26m	< 12m - 29m	< 30m *down wash	< 26m - 42m	Bespoke

Machine Features

- Ideal for tanks from <10m to 26m diam where a dense wash pattern is required
- Safety & quality certified to ATEX / BV standards
- Configured to order, reducing water consumption
- Available in 2 surface finishes: standard & hygienic
- Minimum moving parts for extended operating life, reduced down time & ease of maintenance
- Self-cleaning & lubricating, avoids contamination
- Effective cleaning, even at low operating pressures

Materials of manufacture:-

Body	316L Stainless Steel
Gears	PEEK
Bushes	Carbon PTFE



Technical Information

Max height	312mm
Min tank opening	Ø 125mm
Weight	6 kg
Inlet connection	1.5" BSP
Operating temperature range	Up to 95°C (to 60°C/ATEX)
Cycle times	Variable: approx. 10-17 mins

Typical Scope of Supply

Fixed machine

- 1x Orbitor machine
- 1x Down pipe with mounting flange & valve
- 1x User operation & maintenance manual

Portable machine

- 1x Orbitor machine
- 1x Layflat hose
- 1x Hose saddle
- 1x User operation & maintenance manual



Innovation

that delivers

Document No: SB001 Iss 01 19/02/16

Orbitor 4 Nozzle

industrial & hygienic tank washing machine

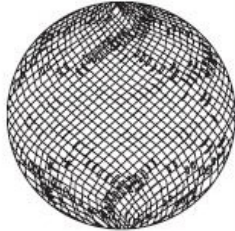

Machine Data

Supply Pressure Kg/cm ²	Jet Length (m) at Nozzle Size (mm)				4 nozzle wash pattern 
	5 mm	6 mm	7 mm	8 mm	
5	6	8	9	10	
6	7	9	10	11	
7	8	10	11	12	
8	9	11	12	13	
9	10	12	13	14	
10	10.5	12.5	13.5	14.5	

Supply Pressure Kg/cm ²	Flow (m ³ /h) at Nozzle Size (mm)				For other nozzle sizes see Orbitor 100 Orbitor Double Nozzle Orbitor Hi Cap	
	5 mm	6 mm	7 mm	8 mm		
5	9.9	12.5	15.3	18.0		
6	10.8	13.8	16.8	19.9		
7	11.4	15.1	18.2	21.7		
8	12.2	16.2	19.6	23.5		
9	12.9	17.6	20.8	25.4		
10	13.5	18.5	22.1	27.1		

Machine Dimensions

Portable Machine

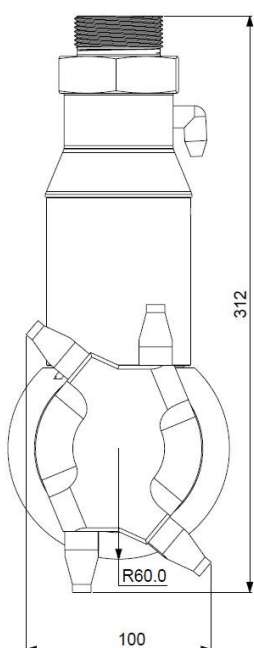

Fixed Machine

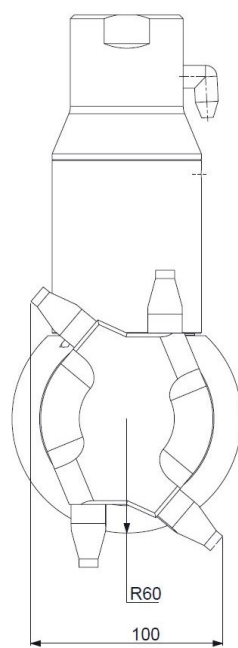

Typical applications

- Food
- Beverage
- Chemical
- Pharmaceutical
- Petrochemical
- Utilities
- Marine
- General small / medium tank cleaning

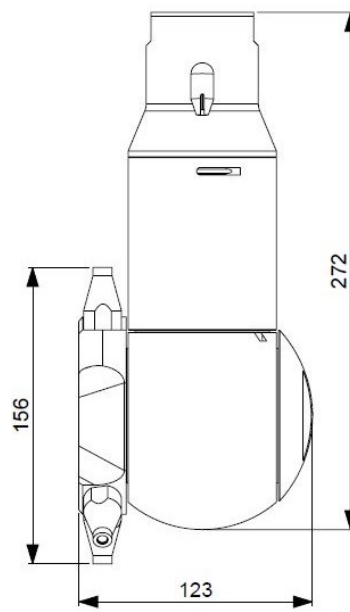

Dasic Tankclean Ltd, Eagle Close, Eastleigh, Hampshire, S053 4NF, United Kingdom.

Tel: +44 (0) 23 80252264 Fax: +44 (0) 23 80266233

Email: enquiries@dasic-tankclean.co.uk Web: www.dasic-tankclean.co.uk

Document No: SB001 Iss 01 19/02/16